

UNIT

07

Electricity & Electronics

CHAPTER 21

Electrostatics

21.1

INTRODUCTION

Electrostatic effects are very common in our everyday experience. Have you ever wondered about peculiar electricity effects? For example, what do the following situations have in common?

- You've greeted your best friend in the library after wandering around looking for books and you both get an electric shock as you touch.
- Removing a synthetic shirt or blouse at night in a darkened room leads to a display of tiny little sparks.
- After travelling in the car you receive a rather nasty little electric shock from the door handle when you get out.

Did you realise that these effects all occur after one type of material has been rubbed against another? Other examples of similar effects:

- Dust always seems to stick to the screen of the television set or computer monitor and gets worse as you try to take it off with a cloth.
- Some cars travel around with funny belts hanging down onto the road.
- Lightning always strikes the oldest and tallest trees in the forest.
- Some groups of balloons never seem to want to stay together properly.
- People sitting on plastic chairs in the office pose a possible danger to sensitive computer or electronic equipment.

These are all due to the presence of electric charge built up on objects around us as a result of frictional processes. This electric charge is very important in nature. Electric forces and charges control many natural effects and are seen in dramatic circumstances such as lightning strikes. Much of our modern technology relies on controlling electric charges, either trying to eliminate their effects or making use of their attracting or repelling properties. In this chapter the aim is to understand the nature of electric charge and the ways in which charge behaves. This will help us to understand the operation of application devices such as spark dischargers, electrostatic generators, photocopiers and fax machines, lightning arrestors and even the various forms of biological electrostatic defences such as those possessed by animals like the electric eels and rays. Physicists regard the force of electricity as a fundamental force of nature that is ultimately responsible for other forces such as **friction**, contact pushes, **adhesion** and **cohesion**.

21.2

ELECTRIC CHARGE

The first step in understanding electrostatic effects is a knowledge of the structure of atoms and matter. Recall that all matter is composed of atoms, which are the building blocks consisting of a very small and dense central nucleus, containing **protons** and **neutrons**, and layer-like regions called clouds surrounding this nucleus, which contain **electrons**. Figure 21.1 shows the relative diameters of a typical atomic nucleus as well as the outer electron cloud

Figure 21.1
Simple model of the atom.

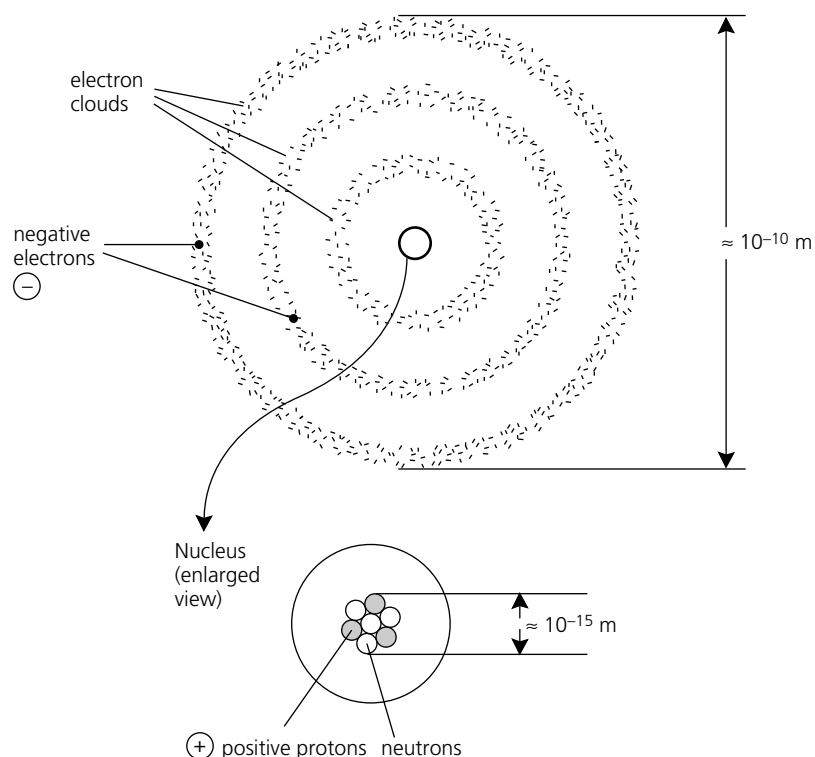

for a general atom. From this type of model it is possible to conclude, as did Lord Rutherford in about 1913 using alpha particle scattering experiments, that the atom is mostly empty space. It is also possible to conclude that the particles within the nucleus are very tightly bound together, with the protons being positively charged and the neutrons being **neutral**, that is, with no net charge. The electrons, especially the outermost ones, are very loosely bound to the nucleus in most atoms and are negatively charged.

Table 21.1 ATOMIC PARTICLE PROPERTIES

	ELECTRON	PROTON	NEUTRON
Relative charge	-1	+1	0
Coulomb charge	-1.6×10^{-19}	$+1.6 \times 10^{-19}$	0
Mass	9.11×10^{-31} kg	1.673×10^{-27} kg	1.675×10^{-27}
Atomic location	orbital cloud	central nucleus	central nucleus
Discovered	1897	1913	1932
	J. J. Thompson	E. Rutherford	J. Chadwick

Table 21.1 compares the properties of the three fundamental atomic particles. Any atom that has equal numbers of protons and electrons is said to be neutral as it will have no net electric charge. Remember that the neutrons act simply as a nuclear glue and do not alter the positive–negative balance of the atom. The simplest atom in nature, the hydrogen atom, only has one electron and one proton, whereas lawrencium, a very complex atom, has 103 electrons, 103 protons and 157 neutrons. If an individual atom of any element is made to gain or lose some of its electron particles then it is said to have become an **ion**. Positive ions have lost electrons and negative ions have gained electrons over and above the normal atomic number. Ions are quite important in various types of chemical reactions.

In electrostatics it is normal to consider blocks of materials that have become **electrically charged**; this means that the material itself, such as a glass rod, has either had

extra electrons placed onto it, or had some of its atomic electrons removed from it. It has thus become net electrically charged or electrified. The ancient Greeks had found that the material they called 'Elektros' attracted bits of hair and small pieces of straw dust when it was rubbed with cloth or animal fur. Today we call this material amber. It is actually fossilised tree resins. Similarly, in laboratory experiments it is easy to show that Perspex rods rubbed with rabbit fur can attract small torn pieces of paper, or that polythene strips if rubbed with the same rabbit fur will subsequently repel each other when freely suspended on a set of free pivots. This type of experiment is often best carried out under a set of heat lamps so as to provide a very dry atmosphere in order to prevent moist ionised air quickly dissipating the electric charges.

This technique of using a cloth or piece of fur to rub a solid such as glass, Perspex, wax or polythene will electrify the object due to a process called 'friction charging'. In this process the energy supplied to the outermost atomic electrons allows them to move from the material with the least affinity or attraction for electrons to that material with the most affinity for electrons. The process is also referred to as **triboelectric** separation of charge. The word is derived from the Greek *tribein*, meaning 'to rub'. Electrons are therefore transferred from one object to another, one object becoming positive as it loses electrons, say the rabbit fur, and the other object becoming negative as it gains electrons, say the polythene strip. Note that in this example of the separation of charge process, the fur will most likely lose its charge quite quickly either by direct contact with the experimenter's hand or by loss to the atmosphere. It will thus regain neutrality. This quite often makes it difficult to show that the fur has in fact become electrically charged.

Table 21.2 TRIBOELECTRIC SERIES

+	Atoms have a low affinity for electrons	
	Rabbit or cat fur	
	Acetate	
	Perspex	
	Glass	
	Wool	
	Lead	
	Silk	
	Paraffin wax	
	Polythene	
	Ebonite	
	Copper	
	Rubber	
	Amber	
	Sulfur	
	Gold	
-	Atoms have a high affinity for electrons	

Every material's atoms have their own specific tendency to gain or lose electrons easily. Table 21.2 lists the triboelectric series showing several materials in order, from those that have a low affinity for electrons and will tend to become positively charged to those that have a high affinity and become negatively charged in frictional experiments. This series is easy to read because any material will become positive by losing electrons if rubbed with any other material lower in the series list. For example, glass can become positively charged when rubbed with a silk handkerchief but negatively charged if rubbed with rabbit fur. Acetate or Perspex rods can become positively charged if rubbed with a woollen cloth while polythene or ebonite rods will become negatively charged when rubbed with the same woollen cloth.

In the triboelectric separation process the frictional charging simply involves a transfer of negative charge or electrons from one object to another. It is important to realise that

Photo 21.1

Free pivot apparatus with charged rods.



NOVEL CHALLENGE

In the mid-1700s, French experimentalist François du Fay observed that a charged gold leaf was attracted by some electrified substances and repelled by others. He called the two types 'vitreous' and 'resinous'. Use Table 21.2 and your knowledge of what substances are classified as vitreous and resinous to decide if the resinous rod would have a positive or negative charge.

PHYSICS FACT

In the eighteenth century, British sailing ships had their gunpowder store (the 'magazine') lined with copper to make it waterproof. Sailors had to put on thick felt slippers to avoid generating a spark by electrification. They learnt this the hard way.

NOVEL CHALLENGE

In 500 BC, Greek philosopher Thales of Miletus noticed that cork dust was attracted to a charged amber rod. It was not until 1500 (almost 2000 years later) that people noticed that after a while the cork dust was repelled. Why was the dust repelled and why do you suspect that people did not notice it earlier?

objects can never gain or lose positive protons in this process. The net amount of charge lost by one object of the pair is gained by the other. We can state a more general law of **conservation of charge** which is:

The net amount of charge produced in any transfer process is zero.

Electric charge is considered to be one of the fundamental properties of matter. Recall that in earlier chapters on force and space physics the idea of an inverse square law of attraction between two masses was established. This force of gravity depended on the value of the respective masses and was inversely proportional to the square of the separation of the masses. Similarly, a force of attraction or repulsion can be detected between electrically charged objects. This force due to electrostatic charge also obeys an inverse square law and depends on the respective amounts of charge on the objects just like the gravitational force between masses. The mathematical form of the **law of electrostatics** is further discussed in Section 21.5 but at this point the most important general features of the law are illustrated in Figure 21.2 and stated as:

Like charges repel and unlike charges attract.

The effects of this law can be observed with charged rods freely suspended on pivot apparatus.

Figure 21.2
Like charges repel and unlike charges attract.

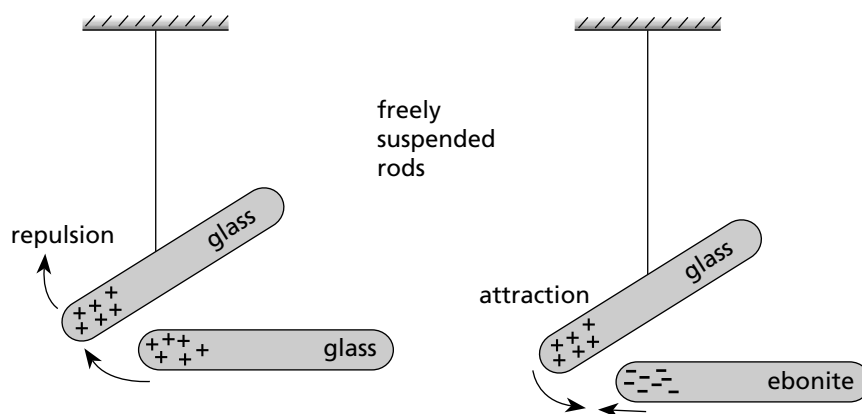
**TEST YOUR UNDERSTANDING**

Plastic food wrap (e.g. Gladwrap) clings because it is electrostatically charged during manufacture.

If this is the case, why doesn't it discharge when you touch it with your hands?

The process of frictional charging can be used in the development of machines that generate and store large quantities of electric charge. Research and experimentation within fields such as materials science, sub-atomic structure of matter, nuclear medicine, atmospheric physics and meteorology require electrostatic generators that provide very powerful force fields and electrostatic potential differences. These topics are further discussed in Section 21.6. A school laboratory machine that usually is a smaller model of the larger more complex research machines is the **Van de Graaff** generator. This device consists of a polished metallic dome that is supported on an insulating column. Charge is transported to or from this dome by a rubberised belt running over a pair of rollers and a system of point combs or knife-edge strips placed very close to the moving belt at the top and bottom. A high-voltage electrical system within the base of the machine continuously provides electrons and a motor rotates the rubberised belt so that charge is moved. As the Van de Graaff generator is operating, charge builds up on the metal dome, eventually producing a very high potential difference between the dome and the Earth. This may reach thousands or even millions of volts. As more charge is moved to the dome the motor has to work harder and reduces in speed. An equilibrium is established when charge movement onto the dome is balanced by charge loss to the surrounding moist air. If any neutral or earthed object is brought close to the dome of the machine it is likely that a single electric spark will jump to the object and the machine will

lose all its built-up charge very rapidly. This is called discharge. (See Photo 21.2.) This effect is similar to the type of process that causes lightning to occur in nature.

The Earth itself is a particularly interesting object electrically. The Earth can be considered as either a source of electric charge or as a sink for electric charge. The process of transferring electric charge to or from the Earth is called **earthing** or grounding and requires an electrical conductor, which is discussed in the next section. Charges are free to move in a conductor either to or from the Earth so that neutrality is maintained. It is common to refer to the process of discharging any electrified object so that it becomes electrically neutral as 'earthing' that particular object.

21.3

CONDUCTORS AND INSULATORS

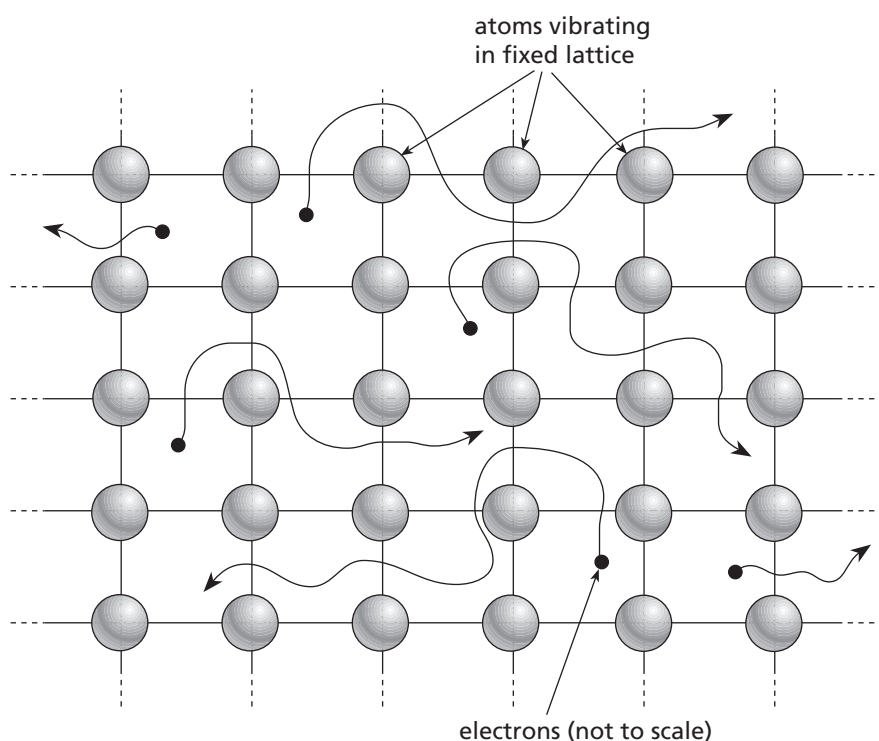

Photo 21.2

Van de Graaff generator.

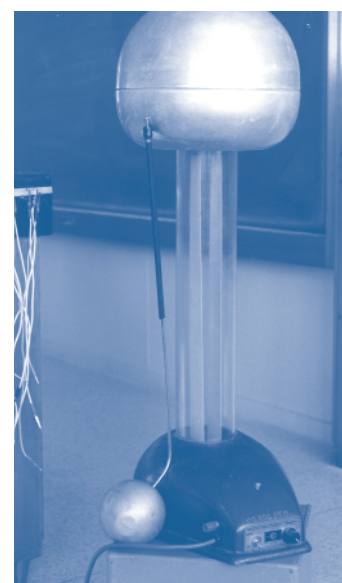

Figure 21.3

Electrons can move freely within the regular lattice arrays of good conductors.

Within solids the atoms are generally arranged in a simple geometric pattern or lattice, whereas in liquids and gases the atoms are much more free to move. A metallic solid has a very regular lattice array of atomic nuclei and the outermost electrons of each atom are quite easily able to move throughout this lattice array. This type of structure is called metallic bonding. (See Figure 21.3.) Metals are called good electrical **conductors** because any charge placed on them is free to move through the lattice. Other substances that do not allow free charge movement, or whose atomic electrons are not free to move, are called **insulators**. Charges that are placed onto any conductor will be free to evenly distribute themselves over the surface of the conductor, whereas charge placed onto the surface of any insulator will stay in the same place. (See Figure 21.4.) The human body acts as a conductor and this is why touching any charged object will lead to the removal of charge from the object.

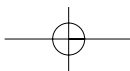

Figure 21.4
Charge movement within
conductors and insulators.

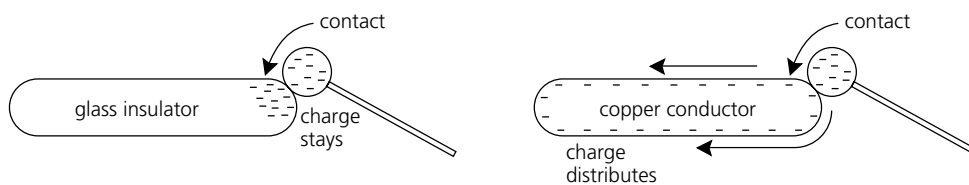
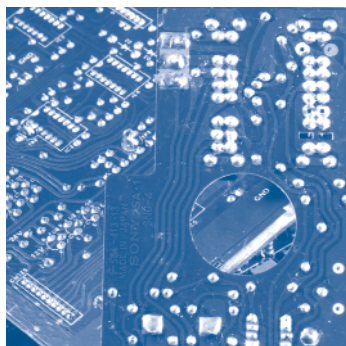
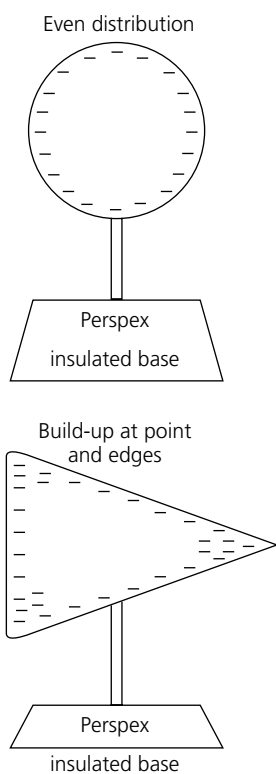

Photo 21.3
Circuit board (copper tracks).



Most metals are very good conductors of electricity, as are liquids that contain charged ions, such as salty water or acid solutions. The most common insulators used to prevent the flow of electric charge are rubber, plastics, paper, glass or ceramics. Insulators are seen in electrical wiring as either a direct coating over the copper conductor or as a stand-off insulating support on power poles in the street. Most household electronic devices have internal circuit boards that contain conducting copper tracks on an insulating fibreglass base. **Semiconductors** are a modern class of materials including silicon, germanium, gallium arsenide and various metal oxides that, in their natural state, are relatively poor conductors compared with metals. However, the conductivity of these crystalline materials can be artificially improved by the addition of selected impurity elements into their crystal structure. This class of semiconductors has become the basis of modern electronic chips and will be discussed more fully in Chapter 23. Their conductivity is variable and can even be switched on and off. Consider what happens when negative charge is placed onto a perfectly symmetrical conductor such as a metal sphere. Remember that the charges are free to move and because they all equally repel each other, they will reside equally distributed over the sphere's surface. If, however, the excess negative charges are placed onto a non-symmetrical (asymmetrical) conductor surface such as a metallic cone, then the charges will repel each other in such a way that they will tend to pile up at the edges and at the point of the cone. As a result, charge leakage to the surrounding air will occur more rapidly at edges and points on a conductor. An important application of this effect occurs with lightning rods or arresters on tall buildings, which allow charges built up during high winds and electrical storms to dissipate very quickly and prevent possible lightning strikes. (See Figure 21.5.)

Figure 21.5
Charge distribution in cross-section over
regular and irregular conductors.



DETECTING AND DEFINING CHARGE 21.4

Figure 21.6
An electroscope detector.

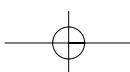
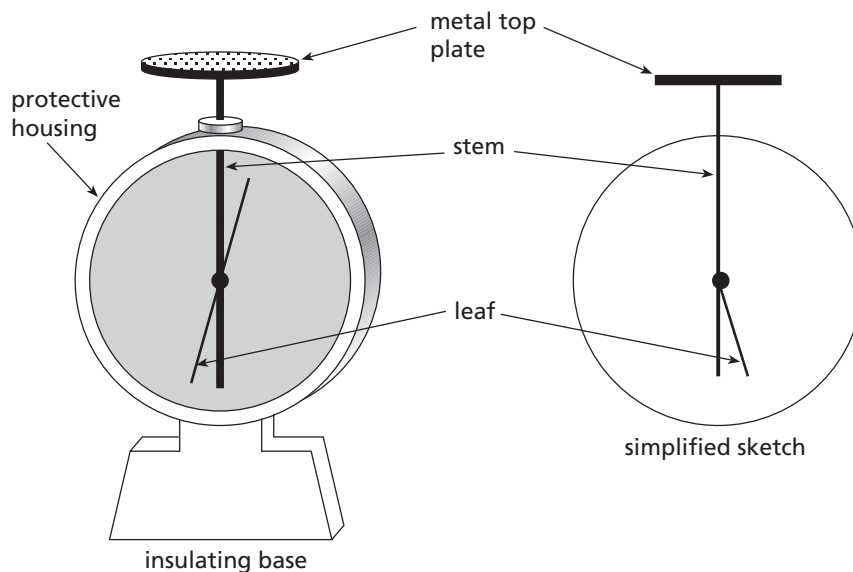

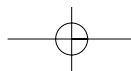

The property of mutual repulsion of like electric charge can be put to use in the design of a simple instrument that will detect the presence of charge. The **electroscope** consists of a metal top plate and stem cased within an insulating protective housing. Attached to the centre stem is either a very fine metal foil strip (leaf) that hangs vertically or a freely pivoted counterbalanced arm. (Figure 21.6.) The electroscope can either detect the presence of charge on any object brought close to the metal plate, or it can be charged itself by contact. If a positively charged rod is brought close to the metal plate, the leaf strip rises as it is repelled away from the stem, as free electrons in the stem and leaf strip are being attracted to the metal plate. If a negatively charged rod is brought close to the metal plate, the leaf strip rises as it is repelled away from the stem again, but this time due to free electrons being forced downward to the leaf strip and the stem. In either case, once the charged rod's influence is removed the leaf strip will collapse back to the stem because no net charge separation within the electroscope occurs (Figure 21.7(a)).

Photo 21.4
IC chips.

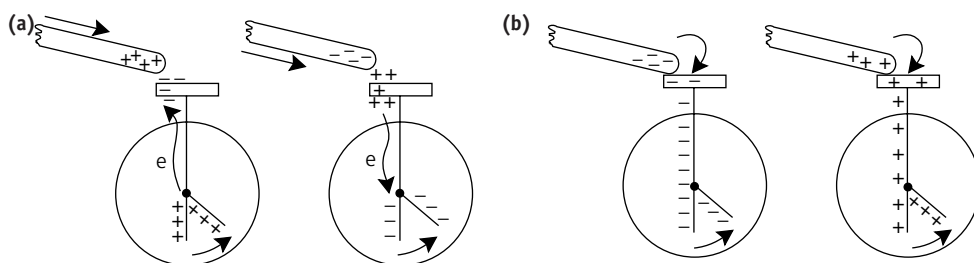
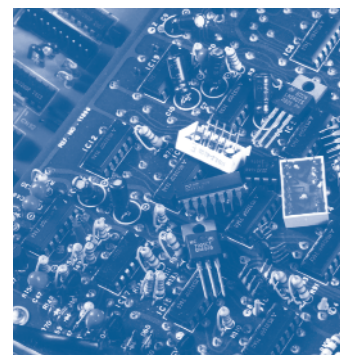

Figure 21.7
(a) Charging an electroscope.
(b) Contacting an electroscope; leaf repulsion will remain.

The electroscope can be charged by contact with the metal plate. If, for example, a positively charged rod touches the top plate and is rubbed across it, the charge is shared with the electroscope. The leaf will be repelled away from the stem, due to equal positive charge and will remain repelled even if the contacted charged rod is removed. Similarly if a negatively charged rod is touched to the plate and rubbed across it, negative charge is shared with the electroscope, and the leaf and stem mutually repel. Again the electroscope will remain charged even if the negative rod is removed (Figure 21.7(b)).

If the electroscope is charged with a known polarity, it can then be used to test for the presence of a charged rod. The leaf of an electroscope of known polarity will fall if a rod of opposite charge is brought into close proximity to the metal plate or will rise further if a rod of similar charge is brought into close proximity. Its leaf will also fall if an uncharged rod is brought near, so the only sure test for a charge is repulsion.

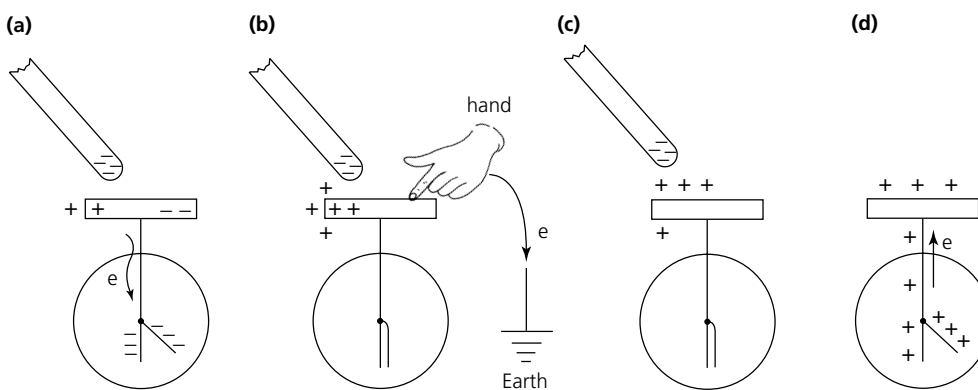
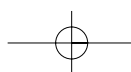
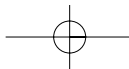

Figure 21.8
Charging an electroscope by induction.

The electroscope can also be charged by a process known as **electrostatic induction**. This involves a stage of earthing the metal plate during the charging sequence. The important fact to remember is that charging an electroscope by induction will always produce an opposite charge polarity between the electroscope and the charged rod used for induction charging. Figure 21.8 shows the steps necessary. Consider a negatively charged rod brought into close





proximity to the metal plate. This repels electrons away from the plate to the leaf and stem and the leaf rises (Figure 21.8(a)). If the metal plate is now earthed, the leaf falls as excess electrons are forced to earth through the hand, leaving the electroscope positively charged (Figure 21.8(b) and (c)). As the hand and then the rod are removed the electroscope leaf and stem again repel due to redistribution of positive charge equally over the electroscope (Figure 21.8(d)).

An interesting device that can be used to provide a source of electric charge is the **electrophorus**. This makes use of both friction charging and earthing techniques. The electrophorus consists of a large plastic or wax baseplate and a metallic disc on an insulating handle, which can sit on the baseplate. To charge the device, the baseplate is rubbed vigorously with woollen cloth or rabbit fur. This creates charge on the baseplate. The metallic disc is grasped by the insulating handle and placed flat down on top of the charged baseplate. Charge separation across the width of the metallic disc occurs due to attraction of the charges on the baseplate. If the top surface of the metallic disc is now earthed momentarily by touch and then the disc is lifted up from the baseplate, the disc will become electrically charged. This device is surprisingly effective in laboratory situations for demonstrating electrostatic effects. (See Figure 21.9.)

Figure 21.9
Charging a simple electrophorus.

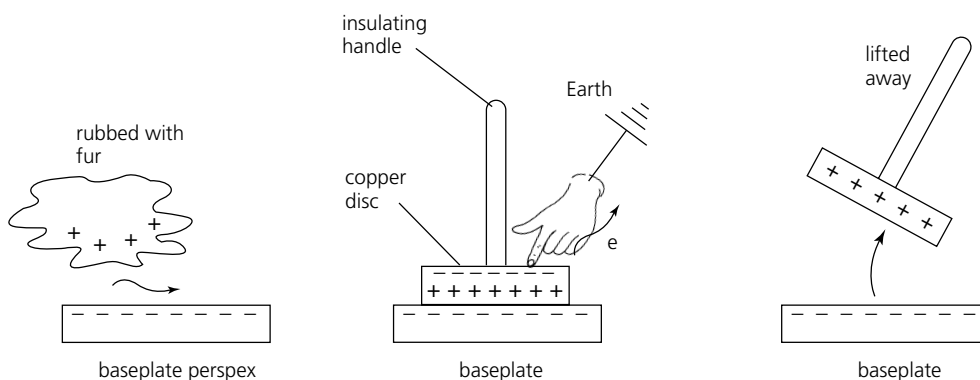

NOVEL CHALLENGE

When sand falls through a plastic funnel onto a metal plate on an electroscope, the leaves diverge. Explain this, if you can.

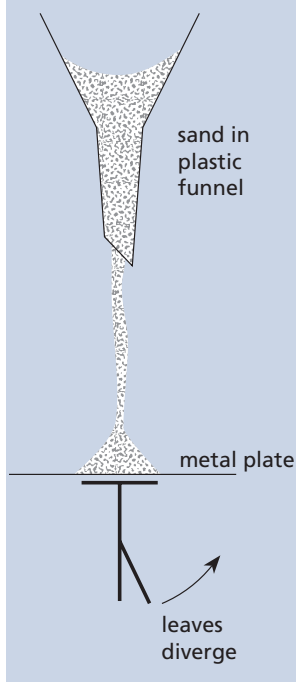

Electric charge is measured in units called coulombs. The unit is named after Charles-Augustin **Coulomb**, a French physicist (1736–1806). One coulomb of electric charge is defined as the charge on 6.25×10^{18} electrons. If an electrified object has an excess of 6.25×10^{18} electrons or has lost this number of electrons, it will have a charge of one coulomb (1 C) negative or positive respectively. This means that the charge on a single electron particle can be calculated as $\frac{1}{6.25 \times 10^{18}} = 1.6 \times 10^{-19}$ C negative. The symbol Q is often used for the quantity of charge on any object.

In practice, with electrically charged objects in the laboratory, very large numbers of electrons are moved. Common units of electric charge become microcoulombs (μC). When charge moves through a metallic conductor at a given rate an **electric current** is produced. By definition, if one coulomb of electrons pass any given point in a conductor per second then a current of one ampere is flowing:

$$1 \text{ ampere (A)} = 6.25 \times 10^{18} \text{ electrons per second}$$

Example

A Perspex rod is rubbed with a piece of silk. It acquires a charge of $0.02 \mu\text{C}$. (a) Is this charge positive or negative and how many electrons are transferred? (b) If all this charge is now transferred to an electroscope with charge $+0.01 \mu\text{C}$, what will be the net state of the electroscope?

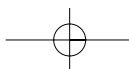

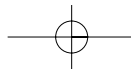

Solution

- (a) By using the triboelectric series, the charge on the Perspex rod is $+0.02 \mu\text{C}$ positive.
- $0.02 \times 10^{-6} \text{ C} = 0.02 \times 10^{-6} \times 6.25 \times 10^{18}$ electrons, or
 - 1.25×10^{11} electrons transferred from Perspex to silk.
- (b) Total charge on the electroscope after transfer = $0.02 \mu\text{C} + 0.01 \mu\text{C} = 0.03 \mu\text{C}$ (positive).
The electroscope leaf deflection will increase and the net charge on the electroscope is now $+0.03 \mu\text{C} = 1.87 \times 10^{11}$ electrons depleted.

Questions

- Use the triboelectric series to describe the outcome of rubbing:
 - glass with silk;
 - rubber with woollen cloth;
 - insulated gold with cat fur.
- Draw a diagram showing the electrostatic outcome of two Perspex rods rubbed with silk cloth and freely suspended in close proximity to each other.
- Draw a set of diagrams to explain the outcome of bringing the following within close proximity of, but not touching, a neutral electroscope:
 - a negatively charged rod;
 - a positively charged rod.
- In a particular chemical reaction an iron atom (Fe) becomes a ferric ion (Fe^{3+}). Determine the charge on this ion in coulombs and describe what has occurred in terms of electron transfer.
- Consider Figure 21.10(a). A and B are identical insulated metal spheres with charges as shown. What is the charge on each sphere after they are touched together and then separated?
- Consider Figure 21.10(b). A and B are insulated metal spheres with charges as shown. If sphere A has twice the radius of sphere B, what will be the charge on each sphere after they are touched together and separated? (Remember, charge resides equally distributed over the surface of a spherical metallic conductor.)

Figure 21.10

For questions 5 and 6.

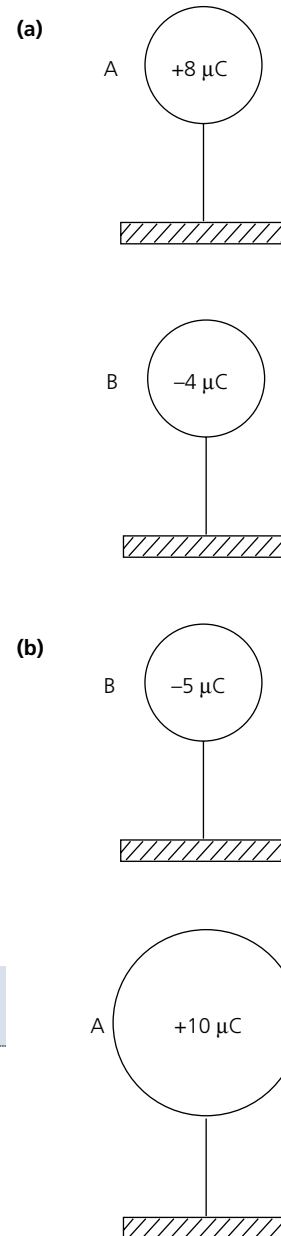

21.5

COULOMB'S LAW

It has been seen that when electrically charged objects are brought into close proximity, there is a force between them that is either attractive or repulsive, depending on the nature of the charges. Charles-Augustin Coulomb in the late eighteenth century used a very sensitive electrostatic torsion bar balance system to investigate the nature of this force. From careful measurements made on the quantity of charge, the distances between charges and the forces acting on the charges, Coulomb was able to show that:

- the magnitude of the force was proportional to the product of the charges
- the magnitude of the force was inversely proportional to the square of the distance separating the charges
- the direction of the force was along a line joining the centres of the charges
- the magnitude of the force was dependent on the medium in which the charges were placed.

These points can be summarised mathematically as:

$$F \propto \frac{Q_1 Q_2}{d^2} \quad \text{or} \quad F = k \frac{Q_1 Q_2}{d^2} \quad \text{for charges in air}$$

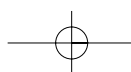

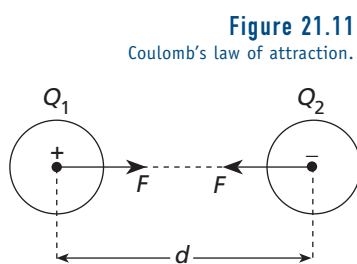
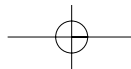

Figure 21.11
Coulomb's law of attraction.

where Q_1 and Q_2 are the charges in coulombs (C); d is the separation of the charges in metres (m); and $k = \frac{1}{4\pi\epsilon_0} = \frac{1}{4\pi \times 8.85 \times 10^{-12}} = 9.00 \times 10^9 \text{ N m}^2 \text{ C}^{-2}$. The constant epsilon-zero is called the 'permittivity of free space'.

This equation is referred to as **Coulomb's law** and it must always be remembered that the force involved is a vector quantity. For two charges in isolation the direction of the force will be repulsive if the charges are the same sign and attractive if the charges are opposite in sign (Figure 21.11).

The vector nature of this law is also very important if a system of two or more charges is considered. In this case it is necessary to determine the resultant electrostatic force in both magnitude and direction using vector addition techniques. In problems dealing with Coulomb's law it is often convenient to consider the charges as point charges. This is possible whenever the separation distance of the charges is very large compared with the size of the charges themselves.

Example

Figure 21.12
System of charges.

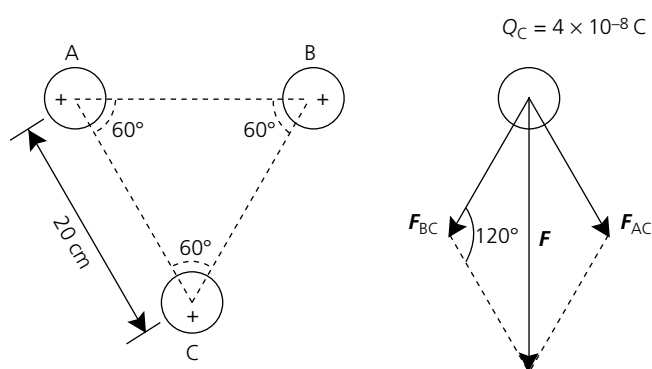

Consider the system of charges as illustrated in Figure 21.12. Deduce the magnitude and direction of the force on charge C. Each charge is $+4.0 \times 10^{-8} \text{ C}$ and they are arranged in an equilateral triangle of side 20 cm.

Solution

The force on charge C will be the vector resultant of both forces labelled F_{AC} and F_{BC} as shown, which are equal to each other in magnitude.

Calculate the magnitude of each force vector:

$$\frac{9 \times 10^9 \times 4 \times 10^{-8} \times 4 \times 10^{-8}}{(0.2)^2} = 3.6 \times 10^{-4} \text{ N}$$

Force (F) may now be calculated using the cosine rule for triangles:

$$\begin{aligned} F^2 &= F_{AC}^2 + F_{BC}^2 - (2 \times F_{AC} \times F_{BC} \times \cos 120^\circ) \\ F^2 &= (3.6 \times 10^{-4})^2 + (3.6 \times 10^{-4})^2 - (2 \times 3.6 \times 10^{-4} \times 3.6 \times 10^{-4} \times -0.5) \\ F^2 &= 3.89 \times 10^{-7} \text{ N} \\ F &= 6.2 \times 10^{-4} \text{ N} \end{aligned}$$

The force is repulsive and will be directed vertically down the page or at an angle of 30 degrees to the line of the force F_{AC} .

Note: this problem may also be solved by dividing the diagram up into smaller right-angled triangles and using simpler Pythagorean calculations.

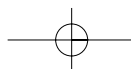

Questions

- 7 Within an atomic helium nucleus, two protons are separated by a distance of 1×10^{-14} m. What is the size of the Coulomb repulsion force between them? Recall that the charge on a proton is the same as the charge on the electron.
- 8 Two point charges A and B each have charge $+Q$ coulombs and are separated by a distance r metres. If the force acting between them is 6×10^{-4} N:
(a) is the force attractive or repulsive; **(b)** what is the force if distance r is doubled; **(c)** what is the force if charge Q on both A and B is doubled; **(d)** what is the force if charge Q on both is halved, but so is the distance between them?
- 9 Four point charges A, B, C and D are arranged on corners of a square of side 25 cm. If A and B each have a charge of $+1 \mu\text{C}$ while C and D each have a charge of $+2 \mu\text{C}$, what is the resultant force on a charge of $+1 \mu\text{C}$ placed at the centre of the square?

21.6

ELECTRIC FIELDS

Like other fields existing in physics, such as a gravitational field, we can define a region containing an **electric field** as that in which any electrified object will experience a force. This makes it a similar concept to a mass experiencing a gravitational force of attraction to, say, the Earth. Electric fields exist in space around electrically charged objects and physicists define both the electric field magnitude or strength and its direction. Electric field strength, E , is thus a vector quantity. The main difference between electric fields and gravitational fields is that the latter only has attractive forces, whereas electrical fields can provide both attractive and repulsive forces.

The magnitude of the electric field, or its electric field strength at any point, is defined as the force acting on a test unit charge placed at that point in the field. The direction of the electric field at any point is given by the resultant force direction acting on a test positive unit charge placed at that point in the field. Thus mathematically, electric field strength is defined with the following equation:

$$E = \frac{F}{q}$$

Electric field strength has standard units of N C^{-1} (newtons per coulomb).

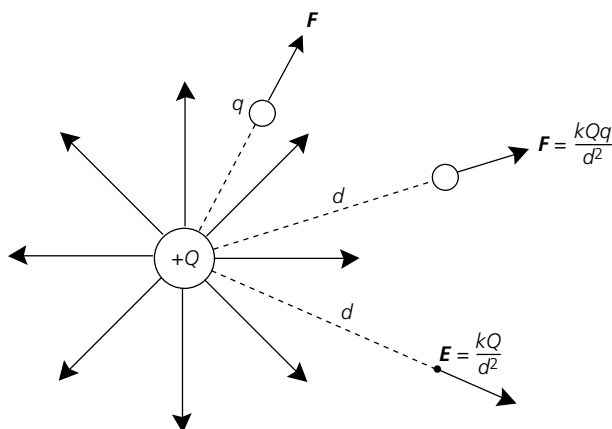

Consider a point source of positive charge, $+Q$, as shown in Figure 21.13. If a small test positive charge, q , was moved around the charge Q , then forces of repulsion would be felt in

NOVEL CHALLENGE

This one is only if you do chemistry as well. In his book, *The Ascent of Science*, Professor Brian Silver says that if you had two sugar cubes and transferred one electron of each billion electrons in one of the cubes to the other cube, the force between the two cubes would equal the weight of boxer Mohammed Ali (1000 N) when the cubes were placed 1 km apart. Sucrose (sugar) has the formula $\text{C}_{12}\text{H}_{22}\text{O}_{11}$ and a molar mass of 342.

Assuming a cube of it has a mass of 5 g, what figure do you get? We get nothing like 1000 N.

Figure 21.13
Electric field diagram surrounding a point charge $+Q$.

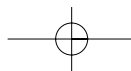
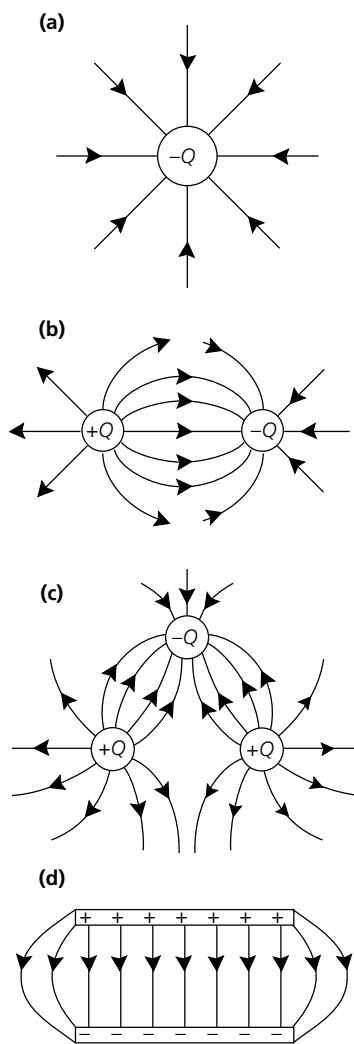

Figure 21.14
Electric field diagrams in cross-section.



radial lines directed outward. The further away q was moved along these lines the weaker the electric field strength would get. At all times the force magnitude would be given by Coulomb's law and thus the electric field strength, E , at some distance d from the charge Q would be:

$$E = \frac{F}{q} = \frac{kQq}{d^2} \times \frac{1}{q} = \frac{kQ}{d^2}$$

and its direction is radially outward.

This equation therefore describes the electric field strength at a point d from a large point charge Q . The electric field strength E is defined as having a value of zero at an infinite distance from the source. Note that Figure 21.13 is representing the nature of the electric field in a two-dimensional cross-section only and the actual zone of influence is always in three dimensions around point charges. Figure 21.14 gives cross-sectional electric field diagrams showing the two-dimensional field lines present in several situations where there may be more than one charge influence involved. It is important to realise that:

- electric field lines never cross, in a diagram
- electric field lines are directed from positive charge to negative charge
- electric field lines will enter or leave any charged surface at right angles
- if electric field lines are close together or more densely packed per unit area, the force per unit charge is much higher, that is, there is greater electric field strength.

Notice that in Figure 21.14(d) the electric field lines between parallel charged plates is very uniform in nature. This uniform electric field will produce a constant force on any test charge held between plates independent of position. In 1909 an American physicist **Robert Millikan** used the very uniform electric field between charged parallel metallic plates to investigate the nature of electric charge itself. Millikan was able to balance the electric force on charged oil droplets sprayed between the plates with the droplets' own gravitational weight. By carefully measuring the mass of these oil droplets and changing their electric charge with X-rays, Millikan was able to calculate a value for the charge on an electron. He won the Nobel prize in physics in 1923 for his work on the electrostatics of elementary charges.

Research work in more recent years has concluded that particles called **quarks** have less electric charge than the elementary electron. Several different types of quarks are thought to exist in theory, making up protons and neutrons. Quarks are postulated to have charges of $+\frac{2}{3}e$ and $-\frac{1}{3}e$ but particle physicists have not yet been able to detect a free quark existing by itself in their research or experiments. (Refer to Chapter 29.)

Figure 21.15
Diagram of point charges A and B.

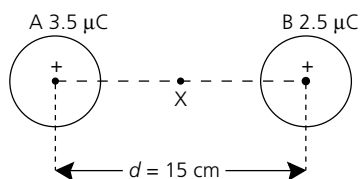

Example

Figure 21.15 shows two point charges A and B separated by a distance of 15 cm.

- Determine the magnitude and direction of the electric field at a point X midway between the two charges.
- Determine the point between the charges at which the electric field strength is zero.

Solution

- The electric field at X is the vector sum of the fields due to each point charge.

$$E_A = k \frac{Q}{d^2} = \frac{9.00 \times 10^9 \times 3.5 \times 10^{-6}}{(7.5 \times 10^{-2})^2} = 5.6 \times 10^6 \text{ N C}^{-1} \text{ toward B}$$

$$E_B = k \frac{Q}{d^2} = \frac{9.00 \times 10^9 \times 2.5 \times 10^{-6}}{(7.5 \times 10^{-2})^2} = 4.0 \times 10^6 \text{ N C}^{-1} \text{ toward A}$$

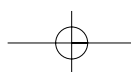

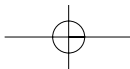

Hence the resultant: $E = 5.6 \times 10^6 - 4.0 \times 10^6 = 1.6 \times 10^6 \text{ N C}^{-1}$ toward B

- (b) The point where the electric field is zero is the point where the electric field E_A is numerically equal to the electric field E_B , but opposite in direction. Let this take place at a distance s from A. Thus:

$$|E_A| = |E_B|$$

$$\frac{9.00 \times 10^9 \times 3.5 \times 10^{-6}}{s^2} = \frac{9.00 \times 10^9 \times 2.5 \times 10^{-6}}{(15 - s)^2}$$

$$3.5 \times 10^{-6} (15 - s)^2 = 2.5 \times 10^{-6} \times s^2$$

$$0.35s^2 - 30s + 225 = 0$$

$$s = 8.1 \text{ cm from A}$$

NOVEL CHALLENGE

Here's a good idea we overheard at a UFO conference. To launch a rocket, it was suggested that 1 gram of hydrogen ions be placed aboard a rocket and then another gram of H^+ ions be wheeled underneath in a wheelbarrow (say 1 metre away). One gram of hydrogen ions (H^+) contains 6×10^{23} particles. So the big positive charge in the rocket would be repelled by the big positive charge in the wheelbarrow (about a billion billion newtons) and this would be sufficient force to launch the rocket. Calculate the force and the initial acceleration of a 100 tonne rocket. What is the major flaw in this design?

21.7

ELECTRIC POTENTIALS

The gravitational field analogy can be used again when discussing the energy stored in an electric field. Recall that in gravitation, work was needed to lift a mass against the direction of the gravitational field and as this work was done, gravitational potential energy was stored in the mass. The energy stored was equivalent to the work done, W , and calculated using $W = mgh$. Similarly, it requires work to be done to move electric charges of the same polarity together, as the force of mutual repulsion is overcome. Consider a point positive charge q moved from infinity towards another point positive charge Q . The force of repulsion is the Coulomb force and the work done in moving the charge q to a point in space at a distance d from the charge Q is given by:

$$W = q \times E \times d$$

Compare this formula with the work done on a mass m in a gravity field g shown above. This relationship for electrical work done is true even though the nature of the Coulomb force of repulsion in the field is not uniform. By using very small incremental distances and mathematical calculus techniques, it is possible to verify that the total work done is the same as the sum of all incremental force by distance calculations.

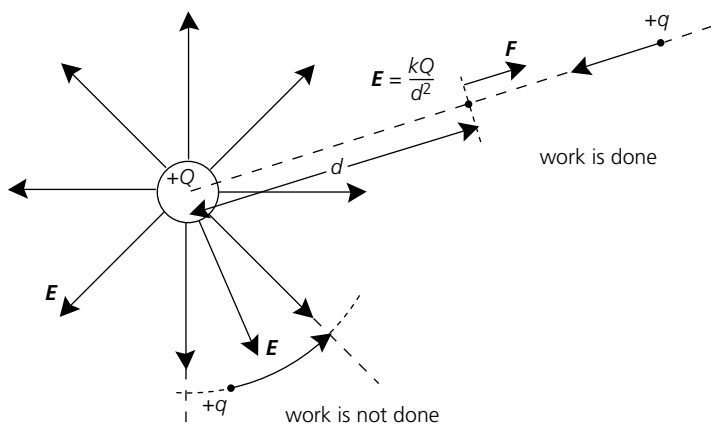
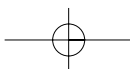
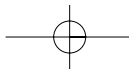

Figure 21.16
Work done within an electric field.





Also remember that because $W = F d \cos \theta$, if the charge is moved perpendicular to the field lines then no work at all will be done. The work done in moving charge q will subsequently store electrostatic potential energy in the charge q . If the repulsive force between the charges is allowed to act by itself then the stored **electrostatic potential energy** will be converted back into kinetic energy of motion. This effect can be made use of in electrostatic charge accelerators, especially when the uniform field of parallel charged plates is present (Figure 21.16).

It is common to refer to the **electric potential** (V) of a point in space within any given electric field. The electric potential V at any point is the work done in moving a unit positive charge from infinity to that point. The electric potential V is thus the electrostatic potential energy stored per unit charge at any given point d from a charge Q . Thus:

$$V = \frac{W}{q} = \frac{q \times E \times d}{q} = E \times d = \frac{kQ}{d}$$

Electric potential at a point is a scalar quantity and is measured in units of joules per coulomb ($J C^{-1}$). One joule per coulomb is also known as a volt. $1 \text{ volt (V)} = 1 J C^{-1}$. Of course, moving unit positive charges from infinity to a point d within the field of a point charge Q is not particularly realistic, and hence the term **potential difference** is more useful in that it describes the difference in potential between two positions within the field, neither of which is at infinity (Figure 21.17). The potential difference is the work done in moving a unit charge from position one in the field to position two in the field.

Figure 21.17
Electric potential difference between two points in a field.

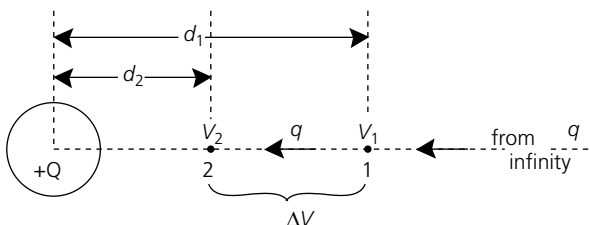

$$\Delta V = V_2 - V_1 = \frac{W_{12}}{q} \Rightarrow W_{12} = q \times \Delta V = q \cdot (V_2 - V_1)$$

Potential differences become very useful in electric circuit work, which will be discussed in the next chapter. If both ends of an electrical conductor are held at different potentials (by connecting to the opposite poles of a battery, say!) then a potential difference is set up across the conductor and the subsequent electric field within the conductor will allow free electrons to flow. This is what is referred to as an electric current within the conductor.

Example

Figure 21.18
Potential difference between two charges.

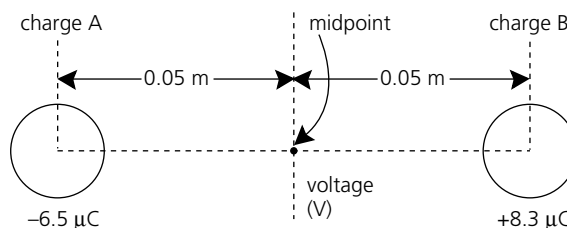

Consider Figure 21.18, with charges A and B of $-6.5 \mu C$ and $+8.3 \mu C$ respectively, in space. If these charges are separated by a distance of 10 cm, find the potential at the midpoint between their centres.

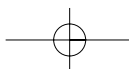

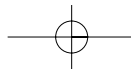

Solution

The potential at the midpoint will be the scalar addition of the potentials due to each charge.

Potential at midpoint due to charge A is:

$$V_A = \frac{kQ}{d} = \frac{9.00 \times 10^9 \times -6.5 \times 10^{-6}}{0.05} = -1.2 \times 10^6 \text{ V}$$

Potential at midpoint due to charge B is:

$$V_B = \frac{kQ}{d} = \frac{9.00 \times 10^9 \times 8.3 \times 10^{-6}}{0.05} = +1.5 \times 10^6 \text{ V}$$

Hence $V_{\text{Total}} = V_A + V_B = 0.3 \times 10^6 \text{ V} = 3.0 \times 10^5 \text{ V}$

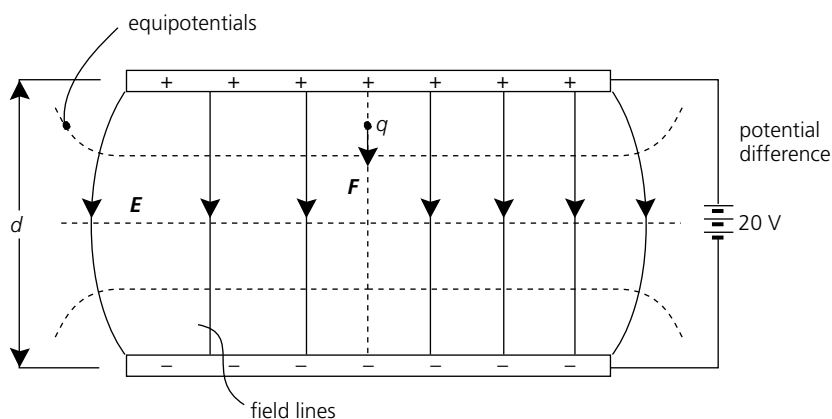

Figure 21.19

Uniform electric field between parallel conductive plates.

Recall in the previous section that the electric field between a set of parallel conductive plates (Millikan plates or a capacitor) is very uniform in nature. Consider now the electric potentials involved in this situation (Figure 21.19). If the plates are separated by a distance d and the potential difference between the plates is maintained by a battery of voltage V , this voltage is the work done in moving a test charge q from one plate to another.

$$V = \frac{W}{q} \quad \text{or} \quad W = q \times V$$

The test charge q would also experience a force in the field and work done against this force to move the charge across the plate separation would be given by:

$$W = F \times d = q \times E \times d$$

Thus within this uniform electric field:

$$q \times V = q \times E \times d \quad \text{or} \quad V = E \times d \Rightarrow E = \frac{V}{d}$$

which defines the electric field strength in the alternative unit of volts per metre (V m^{-1}). Volts per metre are equivalent to newtons per coulomb (N C^{-1}). If lines are drawn in the region between the parallel plates that join points of equal potential, they would be parallel to the plates and spaced equal distances apart. These lines are called **equipotentials**.

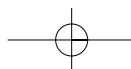

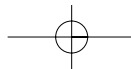

The energy unit used in atomic physics is called the **electron-volt** (eV) and is defined using the fields of parallel plates. If an electron moves across a potential difference of 1 volt, then work done is:

$$W = q \times V = 1.6 \times 10^{-19} \text{ C} \times 1.0 \text{ V} = 1.6 \times 10^{-19} \text{ J}$$

Thus 1 eV = 1.6×10^{-19} J.

It can be seen that this energy unit is considerably smaller than the joule energy unit and as such is useful in atomic structure research. Particles leaving radioactive atoms can possess millions of electron-volts and accelerator machines used in high energy physics laboratories can develop particle energies of giga or tera electron-volts (GeV, TeV).

Example

In a Millikan-type experiment a suspended negatively charged latex sphere has a mass of 5.7×10^{-7} g and is held at rest between the plates with potential difference V of 280 volts. If the plates are separated by a distance of 4.0 mm:

- draw a diagram of the apparatus in cross-section and label the plate polarity correctly;
- calculate the electric field strength;
- calculate the charge on the latex sphere in both coulombs and elementary charges.

Solution

- Plates must be oriented with positive plate uppermost so that the electric field force balances the downward gravitational force.
- Using $E = \frac{V}{d} = \frac{280}{4.0 \times 10^{-3}} = 7.0 \times 10^4 \text{ V m}^{-1}$ down.
- Since the gravitational force balances the electrical force:

$$q \times E = m \times g$$

$$q = \frac{mg}{E} = \frac{5.7 \times 10^{-10} \times 9.8}{7.0 \times 10^4} = 8.0 \times 10^{-14} \text{ C}$$

$$\frac{8.0 \times 10^{-14}}{1.6 \times 10^{-19}} = 5.0 \times 10^5 \text{ electrons}$$

Questions

- Draw the cross-sectional electric field diagram for a system of negative charges, all situated at the corners of an equilateral triangle.
- What is the electric field strength 0.2 m from a point charge of $-6 \mu\text{C}$ in both magnitude and direction?
- A metal sphere of radius 35 cm carries a charge over its surface of $16 \mu\text{C}$. What is the potential at its surface?
- Two points in space are at electric potentials of $+18 \text{ V}$ and -6 V respectively. Calculate (a) the potential difference between these two points and (b) the work done in moving a charge of $5.5 \mu\text{C}$ from one to the other.
- Two metal plates are placed vertically 30 mm apart and a potential difference of 300 volts is applied. (The top plate is positive.)
 - Calculate the electric field between the plates.
 - If a negative charge of $6 \mu\text{C}$ is placed in the field at a point 10 mm above the earth plate, what force acts on it?
 - Calculate the energy gained by the charge as it is moved up to the positive plate.

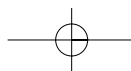

21.8

APPLICATIONS OF ELECTROSTATICS



Activity 21.1 SPECIAL ELECTROSTATIC EFFECTS

Each of the situations described below involves an application of electrostatic cause and effect. Read each short paragraph and try to explain on paper, with diagrams, the physics involved in each application. Answer the questions following each section.

- 1 *Conductive tyres or discharge straps on vehicles* Aircraft and large fuel tanker trucks often have tyres made of conductive rubber so that electric charge built up during travel through the air will discharge quickly to the ground. If this precaution is not available, special conductive straps are attached between the ground and the plane or truck body before any fuel exchange takes place. Some people attach conductive straps to cars, which touch the ground as the car drives along. These straps are to earth the car so that electrostatic charge built up during travel will not cause annoying electric discharges to the passengers as they get out of the vehicle. Would it be better to connect the strap to the ground or to the plane first?
- 2 *Lightning arrestors on tall buildings* During thunderstorms clouds build up very large potentials due to charge separation within the cloud. This effect induces a large build-up of charge onto buildings and objects rising up from the ground, which could act as discharge points or points for lightning to strike. Lightning arrestors are a series of upwardly pointing metal rods or spikes, often ornately shaped, which are connected to a copper earthing strap that runs down the building to the earth. This system allows rapid discharge to the air of charge built up at the top of the building and thus helps to prevent lightning strikes (Figure 21.20).

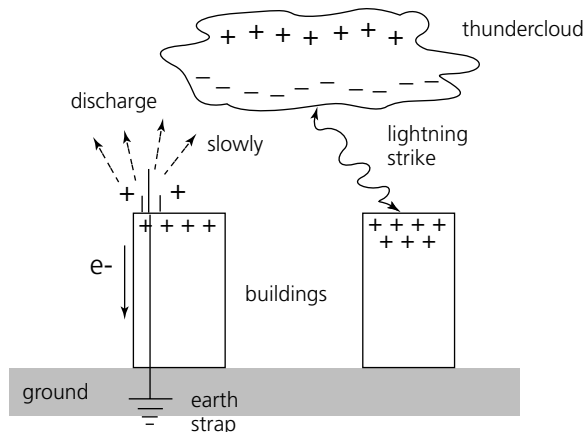

Figure 21.20
Applications of electrostatic principles: lightning arrestors.

Some people think that the arrestors carry lightning strikes to ground after the building has been hit by lightning. Explain whether or not this is true.

- 3 *Factory chimney precipitators* Smokestacks in modern industrial factories are fitted with a system of electrostatic precipitators. These consist of charged plates or helical coils around the top of the chimney stacks, which are held at a high positive electric potential. Smoke and ash debris formed in furnaces is often negatively charged, so that instead of being emitted to the air it is attracted to the plates and coils and precipitates out. This allows for collection of the solid material for periodic cleaning. You can model this effect quite easily with a gas jar full of smoke and several turns of copper wire wound around the body of the gas jar. If an induction coil is then connected across this coil and the central deflagrating metal spoon placed into the gas jar and turned on, the smoke very rapidly dissipates (Figure 21.21). Explain how the smoke particles in the chimney might become charged in the real situation. How are the smoke particles charged in the lab model?

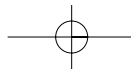
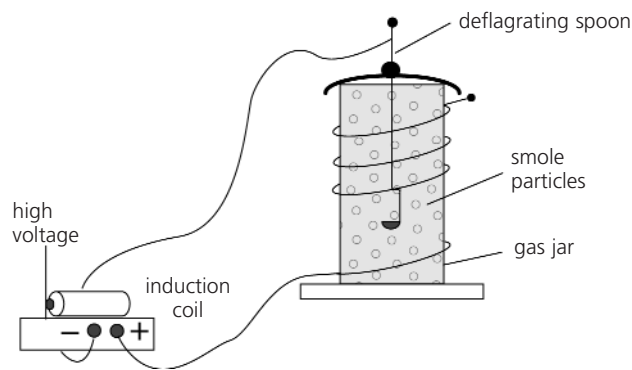
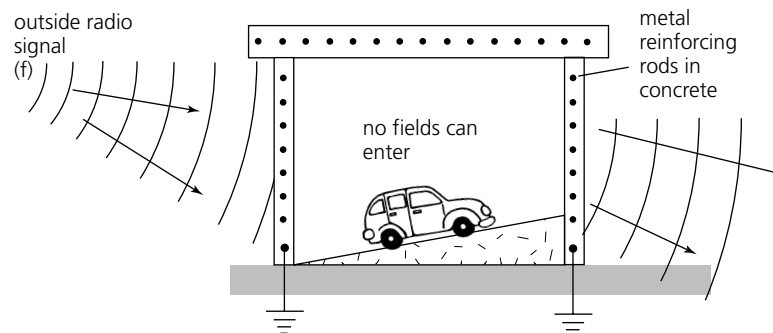

Figure 21.21
Model electrostatic precipitator.



- 4 *Faraday cages preventing radio reception* Have you ever had the experience of listening to your car radio and on entering a large city multi-storey car-park the radio goes weak or disappears altogether? This effect can often occur as you drive across a large enclosed bridge structure such as the Story Bridge in Brisbane or the Sydney Harbour Bridge. These reinforced concrete car-parks or metal bridges are earthed and no electromagnetic fields can enter them; recall that an electric field cannot exist within a hollow metal sphere. Faraday cages, named after Michael Faraday, do not have to be solid structures. An effective electrostatic field protective cage can be made out of metal wire mesh. Often these types of cages are used in the walls of laboratory rooms to help to prevent electrostatic or electromagnetic fields from interfering with sensitive electrical or computing instrumentation. (See Figure 21.22.)

Figure 21.22
Faraday cage effect.



Certain sections of radio and television receiver circuitry are often located inside a metal can housing on the local circuit board. Explain what section of the electronic circuitry is covered up, and why this might be the case.

Interesting applications of electrostatic fields are found in certain species of **electric fish** and rays. The South American eel-shaped fish (*Electrophorus electricus*) and the electric catfish (*Malapterurus electricus*) can deliver shocks from 450 to over 700 volts. Large torpedo rays (numbfish) can produce up to about 200 volts. Gymnotid eels and knife fishes generally produce much lower voltages in pulses from about 30 to 1700 hertz, which set up electric fields around their bodies. All these fish generate electricity in modified muscle tissue bundles called electroplates, located on both sides of their bodies. Stimulated by the autonomic nervous system these muscles generate large electric pulses instead of contracting as normal muscles do. The more powerful electric discharges can certainly stun or even kill prey directly; however, in the main, the specialised sensory nerves within the animal are sensitive to disturbances of the electric field surrounding it. Thus the fish uses the electric field it generates as a type of radar system to locate prey at night or in muddy waters.

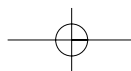

A common machine in offices, schools and businesses today is the **electrostatic photocopier**. A charged plate within the machine receives a light reflected copy of the original page. The reflected dark image from the original causes the plate to remain charged in those areas that are copies of the original typing or diagrams. Carbon black is attracted to these charged areas of the plate and transferred to paper as it is pressed against it. The final step is to heat the carboned paper so that the powdered carbon is fused to the paper and made permanent. You will have noticed that if the photocopier is not working properly, the carbon black on the photocopy smudges easily or wipes off.

An **electron gun** is an assembly that forms the centre of instruments such as a cathode ray oscilloscope (CRO), a television picture tube (CRT) or computer monitor, as well as an accelerating device for particle accelerators (Figure 21.23). Electrons are boiled off the heated filament wire and enter the evacuated space between a pair of charged parallel plates. The voltage across these plates provides a field and an electrostatic force that accelerates the electrons from rest across the gap. The electrons are moving at very high speeds and continue on through an opening in the positive grid plate. Once the electron beam leaves the gun assembly it can be further controlled by electric or magnetic fields, such as occurs in a television tube, to provide the observable image on the screen. Formulae studied so far can be used to predict the kinetic energy and thus the velocity of the electron as it leaves the gun assembly. If the accelerating voltage is V and the charge on the electron is q_e then the work done by the accelerating force is converted into kinetic energy of the moving electron, thus:

$$q_e \times V = \frac{mv^2}{2} \Rightarrow v = \sqrt{\frac{2 \times q_e \times V}{m}}$$

This is referred to as the electron gun velocity formula, but it could be applied to any charge q of mass m accelerated through a potential difference V .

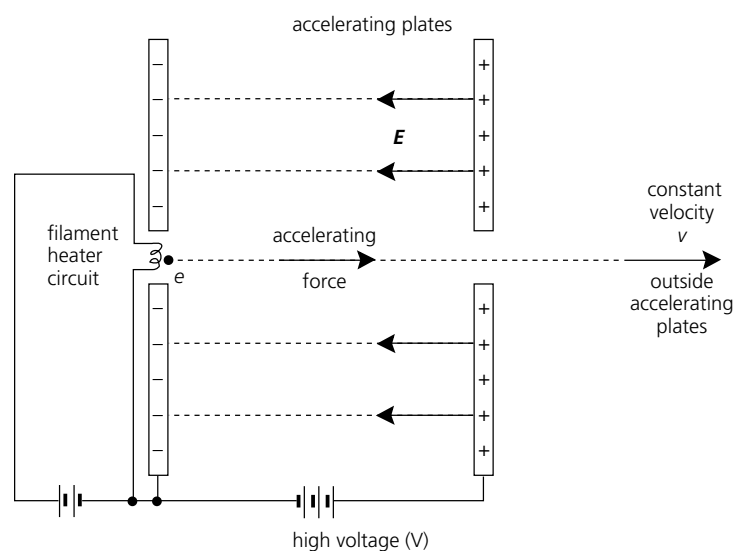

Figure 21.23
An electron gun assembly.

Example

If the accelerating voltage in an electron gun assembly is 350 volts, determine the kinetic energy of the electrons as they leave the gun and the velocity of projection into the evacuated space outside the gun plates.

Solution

Kinetic energy of the electrons equals the work done as they cross the potential difference:

$$W = q_e \times V = 1.6 \times 10^{-19} \times 350 = 5.6 \times 10^{-17} \text{ J}$$

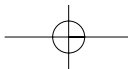

This work done equals the exit kinetic energy, so if the mass of the electrons is 9.11×10^{-31} kg, then using the formula derived:

$$5.6 \times 10^{-17} = \frac{mv^2}{2} = 9.11 \times 10^{-31} \times \frac{v^2}{2}$$

$$v = \sqrt{\frac{2 \times 5.6 \times 10^{-17}}{9.11 \times 10^{-31}}} = 1.1 \times 10^7 \text{ m s}^{-1}$$

— Practice questions

The relative difficulty of these questions is indicated by the number of stars beside each question number: * = low; ** = medium; *** = high.

Review — applying principles and problem solving

- *15** Explain why a balloon rubbed with a piece of woollen cloth might stick to a wall notice-board without falling.
- *16** State the charge on both materials if a piece of Perspex plate is rubbed with a silk cloth.
- *17** Explain the movement of charge when a negatively charged Van de Graaff generator is momentarily earthed by touching it.
- *18** Two charges repel with a force of 2.8×10^{-1} N. If one charge is $+6.5 \times 10^{-6}$ C and they are separated by 0.8 m in air, what is the value of the second charge?
- *19** If a charge of $15 \mu\text{C}$ experiences a force of 750 N when placed in an electric field, deduce the strength of the field in correct units.
- **20** An oil droplet experiences an electrostatic force of 5.6×10^{-14} N when placed into a uniform electric field of 4000 volts per metre. What is the magnitude of the oil droplet's charge?
- **21** Two small metal-coated styrofoam spheres each of mass 2.80×10^{-6} kg are attached to nylon threads 45.0 cm long and hung from a common point. The spheres are then charged equally negative and the angle each supporting thread makes with the vertical is 16° . Calculate the charge on each sphere.
- **22** A metal sphere carries a charge of $20 \mu\text{C}$. If it has a diameter of 20 cm, what will be the potential, V , at its surface?
- *23** Find the electric potential at a radial distance of 1.6 m from a point source of charge of value $+8.2 \mu\text{C}$.
- **24** Two metal plates are oppositely charged and are separated by a distance of 4.5 mm in a vacuum. If a voltage of 520 V is connected across the plates, with the top plate positive, what is **(a)** the strength of the electric field between the plates; **(b)** the force on a test charge having an excess of 50 electrons on it placed between the plates?
- **25** An electron in the gun of a CR tube is accelerated by a potential of 3.0×10^3 V. What is the kinetic energy of the electron in eV and J? What is the exit speed of the electron from the CR tube gun?

- **26** A positively charged ion particle of mass 9.60×10^{-26} kg enters a uniform electric field of strength 20 N C^{-1} at right angles with an initial speed of 1200 m s^{-1} , as shown in Figure 21.24. If the ionic charge is 8.0×10^{-19} C:
- calculate the magnitude and direction of the force on the charged ion;
 - calculate the acceleration of the ion particle in the field;
 - calculate the time of travel of the ion particle in the field;
 - calculate the final displacement and velocity in the direction of the field;
 - describe the probable path of the ion particle in the field.

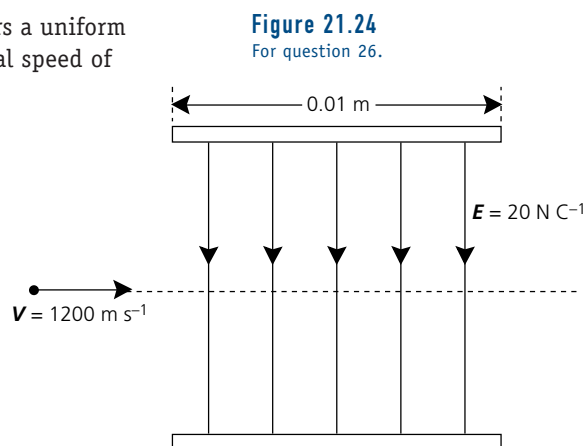

- **27** The shaded area in Figure 21.25 represents an isolated charged metal object in cross-section. The surrounding lines are equipotentials. Use the diagram to analyse:
- near which point the electric field is strongest;
 - the potential difference between A and B;
 - the potential difference between A and C;
 - the energy lost in moving a charge of $+4.5 \times 10^{-9}$ C from C to A;
 - the energy gained in moving the same charge from A to D.

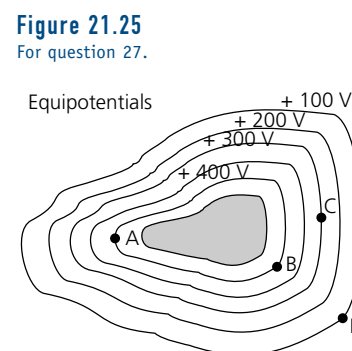

- *28** What is meant by the phrase 'The Earth has zero potential'? Research this idea and report the outcome diagrammatically.
- *29** Draw a sequence of diagrams to illustrate a technique for charging an electroscope negatively using an induction technique.
- **30** In an experiment to replicate Coulomb's original experiment with electrostatic charges, a student set up a torsional balance as shown in Figure 21.26. The apparatus enabled the student to measure the twist in the suspension wire as the 'free' charge tried to rotate away from the fixed charge. From the value of the twist, the student derived a value for the electrostatic force of repulsion between the two spheres. Part of the student's data is shown in the data table. Unfortunately, two of the data points have been obscured by a chocolate smudge.
- Using graph paper, plot a graph to show the relationship between the electrostatic force and the separation distance.
 - From your data, estimate the two readings obscured by the chocolate smudge.
 - What relationship between the force and the distance is suggested by your graph? Explain your answer.

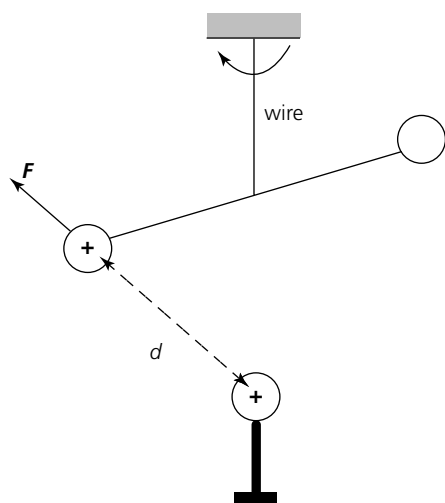

DATA TABLE



Av. Force	Separation
28.4 units	0.75 cm
16.0	1.00
10.2	1.25
	1.50
	1.75
4.00	2.00
1.80	3.00
1.00	4.00

Figure 21.26
For question 30.



- (d) How would you check your hypothesis given in answer (b)?
- (e) Carry out the suggestion you made in (d).
- (f) Suggest how the distance between the centres of the two spheres could have been measured.
- (g) Explain why the student would have made repeated measurements instead of just one reading in each case.

Extension — complex, challenging and novel

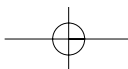
*****31** Two charged particles Q ($+2.5 \mu\text{C}$) and q ($+1.0 \mu\text{C}$) are separated by varying distances, d , and their mutual force of repulsion, F , is measured. Tabulated data are presented below:

F (N)	2.3	0.36	0.14	0.06	0.04	0.028
d (m)	0.1	0.25	0.4	0.6	0.85	0.9

- (a) Which of these data points is in greatest error?
- (b) Determine graphically a value for the Coulomb constant k .

- ***32** Figure 21.27 represents a simplified diagram of the evacuated interior of a computer monitor's CR tube. Electrons are accelerated from the gun filament, pass through point X and enter the region between the deflecting plates YY_1 , before finally striking the screen. If the electron mass is $9.1 \times 10^{-31} \text{ kg}$:
- (a) calculate the time of travel within the deflecting region YY_1 ;
 - (b) state the vertical displacement of the electron in the deflecting region YY_1 ;
 - (c) what is the electron velocity as it reaches the screen at the end of the CR tube?

Figure 21.27
For question 32.

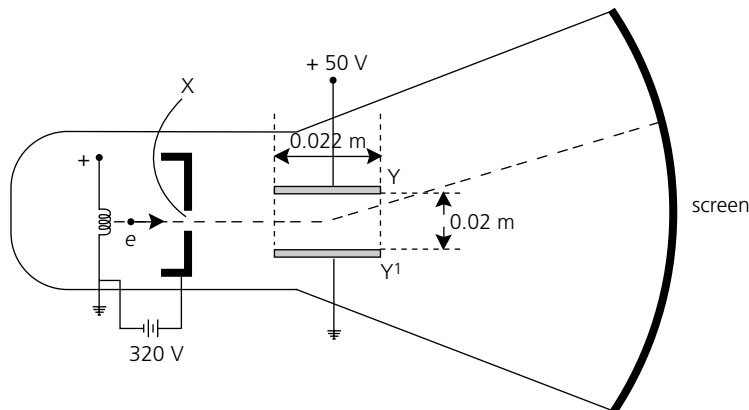
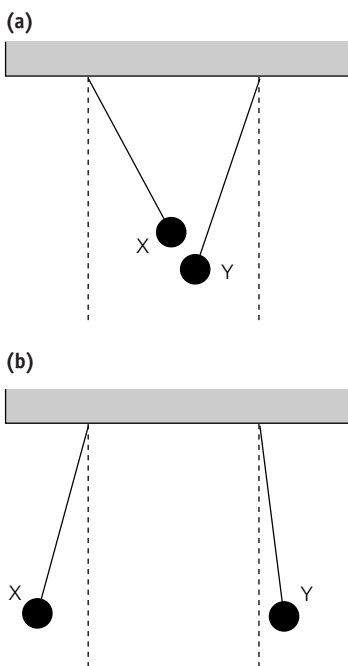

Figure 21.28
For question 33.



- ***33** Two metal-coated spheres X and Y are suspended from light insulating threads of equal length. The spheres are of equal radii, and each carries an electric charge. Figure 21.28(a) shows the positions of the charged spheres at equilibrium. If the two spheres are touched together and then separated they come to rest in new equilibrium positions, as seen in Figure 21.28(b). A student who was asked to explain these results makes the following 'correct' deductions:
- (a) The sign of the charges on the two spheres was not the same.
 - (b) The magnitude of the charges on the two spheres was unequal.
 - (c) The mass of sphere X was less than that of sphere Y.
- Use the information contained in the figures to justify each of the student's deductions.

